

GalvaCorr[®]

A New Versatile Concept in Cathodic Protection

Developed and Patented by NASA



CORTEC
CORPORATION

Environmentally Safe VpCI[®]/MCI[®] Technologies



A New Type of Galvanic Protection

Developed and Patented by NASA

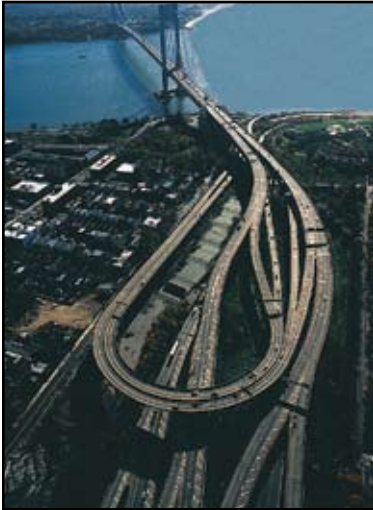

A new reinforced concrete structure is designed to have a long service life – typically in excess of 50 years. Unfortunately, many structures fall short of this goal, requiring expensive repair and protection work in the future.

*A major reason for the premature deterioration of our reinforced concrete infrastructure is **corrosion** of the reinforced steel.*

Galvanic protection of embedded steel rebar for existing structures. Suppresses corrosion in carbonated and chloride-contaminated concrete. Extends life of concrete structures.

Galvanic protection of embedded steel rebar for existing structures. Suppresses corrosion in carbonated and chloride contaminated concrete and extends life.

GalvaCorr® is a three component moisture cured metallic rich coating. The new coating provides cathodic protection and when connected to the steel rebar galvanically stops corrosion.

- Can be applied by spray, brush or roll coating.
- Recommended for bridges, decks, ramps and garages.
- Can be applied to uneven surfaces and to the underside of structures.

The use of a sacrificial metal to protect another metal goes back a century. This proven technology has been used in many forms. Now there is a new form available to protect the embedded steel rebars in concrete structures.

GalvaCorr® is a room temperature liquid coating that can be sprayed or hand applied to concrete structures. It is easily applied to vertical, horizontal and overhead surfaces. The coating can be applied to structures of many shapes.

GalvaCorr® can reach the rebar corrosion process electrically, inside the concrete to slow or stop this internal destruction. Without this galvanic protection, embedded steel/concrete structures may continue to deteriorate until failure.

GalvaCorr® galvanic protection is 30-50% less expensive than 3M's Zinc Hydrogel Anode System



Since GalvaCorr® is 90% metal, scratching the surface of the coating will reveal a metallic sheen.



Note rust bubbling out at the base of the rebar on the sample that is not connected to the coating for galvanic protection. These samples were in a humidity chamber for six months.



An Innovation that Fights Corrosion and Extends the Service Life of Reinforced Concrete Structures



Underside application by the St. Paul traffic department on the 30 year old bridge on Maryland Ave. The GalvaCorr® was hand applied with rollers. The project included sandblasting, excavating to connect the rebar and to assess the condition of the rebars, applying the coating wires and then the coating.



This is the finished coating and wiring system. A small junction box is visible above the ladder. This box is used to take the system readings. A St. Paul Department observation was: "There is nothing to vandalize or steal."



Here, the almost invisible current collecting wires of the coating are highlighted. Part of the insulated current return wire to the rebars is visible over the pier arch.

Cathodic Protection Diagram

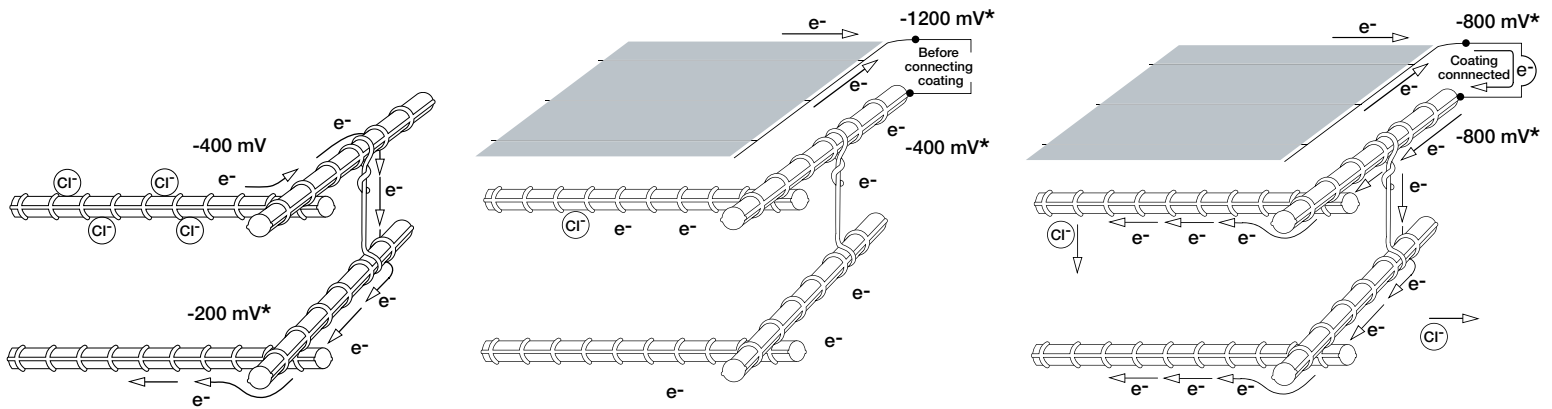

Chloride concentration differences in concrete cause electro-chemical corrosion.

This corrosion converts the steel rebar into rust.

* Potentials if rebars were not connected.

The liquid applied galvanic coating provides a large anodic surface area. This large anodic area assures galvanic protection of the embedded steel rebar.

Connection wires are attached to the concrete surface. The coating is applied over the wires.

* To copper sulfate reference cell

When the GalvaCorr® galvanic coating is electrically connected to the rebar, a galvanic current begins. The higher negative potential on the rebar repels the negative chloride ions. The corrosion to the rebar is suppressed.

* To copper sulfate reference cell

PRODUCT	DESCRIPTION	COVERAGE	PACKAGING	APPLICATIONS
GalvaCorr®	GalvaCorr® is a galvanic coating for concrete that uses metallic particles to provide cathodic protection of the steel rebar. GalvaCorr® is electrically connected to the rebar and galvanically stops corrosion.	150 sq. ft./gal. (3.6 m ² /L)	52 lb./ 3.9 gal. kit (23.6 kg./ 14.82 l kit)	Bridges, parking decks, ramps, garages, concrete piers, offshore platforms, piles, pillars, pipes, buildings, foundations and underside application to structures

Total Corrosion Control

Cortec® Corporation is dedicated to controlling corrosion at ALL STAGES of a product life cycle. Cortec® has developed a diverse range of corrosion protection products including cleaners, metalworking fluids, water- and oil-based coatings and corrosion inhibitors, rust removers, paint strippers, powders, packaging foams, paper, films and surface treatments and admixtures for concrete. Contact Cortec® for additional brochures and information.

LIMITED WARRANTY

All statements, technical information and recommendations contained herein are based on tests Cortec® Corporation believes to be reliable, but the accuracy or completeness thereof is not guaranteed.

Cortec® Corporation warrants Cortec® products will be free from defects when shipped to customer. Cortec® Corporation's obligation under this warranty shall be limited to replacement of product that proves to be defective. To obtain replacement product under this warranty, the customer must notify Cortec® Corporation of the claimed defect within six months after shipment of product to customer. All freight charges for replacement product shall be paid by customer.

Cortec® Corporation shall have no liability for any injury, loss or damage arising out of the use of or the inability to use the products.

BEFORE USING, USER SHALL DETERMINE THE SUITABILITY OF THE PRODUCT FOR ITS INTENDED USE, AND USER ASSUMES ALL RISK AND LIABILITY WHATSOEVER IN CONNECTION THERE WITH. No representation or recommendation not contained herein shall have any force or effect unless in a written document signed by an officer of Cortec® Corporation.

THE FOREGOING WARRANTY IS EXCLUSIVE AND IN LIEU OF ALL OTHER WARRANTIES, EXPRESS, IMPLIED OR STATUTORY, INCLUDING WITHOUT LIMITATION ANY IMPLIED WARRANTY OF MERCHANTABILITY OR OF FITNESS FOR A PARTICULAR PURPOSE. IN NO CASE SHALL CORTEC® CORPORATION BE LIABLE FOR INCIDENTAL OR CONSEQUENTIAL DAMAGES.



Distributed by:

4119 White Bear Parkway, St. Paul, MN 55110 USA
 Phone (651) 429-1100, Fax (651) 429-1122
 Toll Free (800) 4-CORTEC, E-mail info@cortecvci.com
 Internet <http://www.CortecMCI.com>

printed on recycled paper ♻️ 100% post consumer

Revised: 02/09 Supersedes: 05/06
 Cortec®, BioCorr®, BioCortec®, BioCushion™, Boiler Lizard®, Closed Loop Toad®, Cooling Tower Frog®, VpCl®, VpCl® Film Color of Blue®, VpCl-126®, VpCl-609®, VpCl-137®, VmCl-307®, EcoWorks®, EcoAir®, Eco-Corr®, EcoLine®, EcoClean®, EcoShield®, EcoWeave®, EcoSpray®, EcoCoat®, Eco Emitter™, EcoSol™, Eco-Tie™, Eco-Card™, Eco-Shrink™, EcoWrap®, Eco Film®, Cor-MiH®, Cor-Pak®, CorShield®, CorSol®, Corrosorbors®, CorWipe®, CorVerter®, Cor Seal®, CorLam®, Cor-Fill™, CorLube™, CRI®, Desicorr®, ElectriCorr®, GalvaCorr®, Super Corr®, HPRS®, CRI®, MCI®, MCI Grenade®, Milcorr®, Nano VpCl™, and Rust Hunter® are trademarks of Cortec® Corporation.
 ©Cortec Corporation 2009. All rights reserved.